



CH-2538TXWPKD

4K UHD HDMI/VGA over HDBaseT Wallplate Transmitter

CH-2527RX

4K UHD HDMI over HDBaseT Receiver

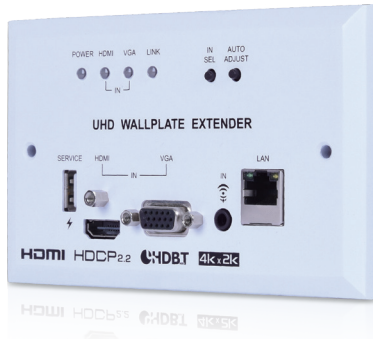

Operation Manual

DISCLAIMERS

The information in this manual has been carefully checked and is believed to be accurate. Cypress Technology assumes no responsibility for any infringements of patents or other rights of third parties which may result from its use.

Cypress Technology assumes no responsibility for any inaccuracies that may be contained in this document. Cypress also makes no commitment to update or to keep current the information contained in this document.

Cypress Technology reserves the right to make improvements to this document and/or product at any time and without notice.

COPYRIGHT NOTICE

No part of this document may be reproduced, transmitted, transcribed, stored in a retrieval system, or any of its part translated into any language or computer file, in any form or by any means—electronic, mechanical, magnetic, optical, chemical, manual, or otherwise—without express written permission and consent from Cypress Technology.

© Copyright 2018 by Cypress Technology.

All Rights Reserved.

TRADEMARK ACKNOWLEDGMENTS

All products or service names mentioned in this document may be trademarks of the companies with which they are associated.





SAFETY PRECAUTIONS

Please read all instructions before attempting to unpack, install or operate this equipment and before connecting the power supply.

Please keep the following in mind as you unpack and install this equipment:

- Always follow basic safety precautions to reduce the risk of fire, electrical shock and injury to persons.
- To prevent fire or shock hazard, do not expose the unit to rain, moisture or install this product near water.
- Never spill liquid of any kind on or into this product.
- Never push an object of any kind into this product through any openings or empty slots in the unit, as you may damage parts inside the unit.
- Do not attach the power supply cabling to building surfaces.
- Use only the supplied power supply unit (PSU). Do not use the PSU if it is damaged.
- Do not allow anything to rest on the power cabling or allow any weight to be placed upon it or any person walk on it.
- To protect the unit from overheating, do not block any vents or openings in the unit housing that provide ventilation and allow for sufficient space for air to circulate around the unit.

REVISION HISTORY

VERSION NO.	DATE	SUMMARY OF CHANGE
VS1	19/01/18	Final technical review
VS2	22/01/18	Additional RS-232 commands
VS3	26/01/18	Remotely RS-232 control only



CONTENTS

1. Introduction	1
2. Applications	2
3. Package Contents	2
4. System Requirements	2
5. Features	3
6. Operation Controls and Functions	5
6.1 Transmitter's Front Panel	5
6.2 Transmitter's Rear Panel.....	6
6.3 Receiver's Front Panel.....	7
6.4 Receiver's Rear Panel	7
6.5 RS-232 Protocol.....	8
6.6 RS-232 Commands.....	8
7. Connection Diagram	12
8. Specifications	13
8.1 Transmitter's Technical Specifications... ..	13
8.2 Receiver's Technical Specifications	14
8.3 Video Specifications	15
8.4 Cable Specifications	17
9. Acronyms	18





1. INTRODUCTION

Transmitter

This Transmitter is an HDMI/VGA switch with audio embedding and HDBaseT output. The wall plate is designed for use with UK two-gang sized enclosures. This Transmitter can send high definition uncompressed audio/video along with Ethernet over a single cable up to a distance of 100 meters at 1080p@60Hz.

The HDMI input supports resolutions up to 4K@60Hz (4:4:4, 8-bit). The VGA input supports resolutions up to WUXGA (RB) and with the use of the associated 3.5mm audio input, stereo audio may be embedded as well. To provide maximum compatibility with a wide range of display types, all sources will be automatically scaled to match the preferred resolution and timing of the connected display (as reported by the display's EDID). Despite HDBaseT's 10.2Gbps bandwidth limitation, even 4K UHD HDMI video sources, up to and including 4K@60Hz (4:4:4, 8-bit), can be supported by converting the signal to 4K@30Hz when necessary.

This unit also supports automatic input selection between the HDMI and VGA inputs, with hot plug detection, enabling hands-free operation. Additionally, the unit may be powered locally or via 48V PoH (Power over HDBaseT) from a compatible HDBaseT Receiver, which allows for greater flexibility in installations.

Receiver

This receiver is a great solution for extending uncompressed HD audio and video as well as Ethernet and control via a single run of Cat.5e/6/7 cable over distances of up to 100 meters. Multiple data and control interfaces are provided, including Ethernet, IR and RS-232 connections. This Receiver complies with the advanced HDCP 2.2 and HDMI 2.0 standards, as well as supporting the legacy HDCP 1.x and HDMI 1.x standards. This Receiver (PSE) can provide 48V PoH (Power over HDBaseT) to compatible Transmitters allowing for greater flexibility within different installation scenarios.

2. APPLICATIONS

- Household entertainment sharing and control
- Lecture room display and control
- Showroom display and control
- Meeting room presentation and control
- Classroom display and control

3. PACKAGE CONTENTS

- 1×HDMI/VGA over HDBaseT Transmitter (with LAN support)
- 1×HDMI over HDBaseT Receiver (with LAN support)
- 1×48V/0.83A DC Power Adaptor
- 1×Power Cord
- 1×Operation Manual

4. SYSTEM REQUIREMENTS

- HDMI source equipment such as a media player, video game console or set-top box.
- HDMI receiving equipment such as an HDTV, monitor or audio amplifier.
- The use of industry standard Cat.6, Cat.6a or Cat.7 cable is highly recommended.
- The use of "Premium High Speed HDMI" cables is highly recommended.



5. FEATURES

Transmitter

- HDMI 2.0 and DVI 1.0 compatible
- HDCP 2.2 and HDCP 1.x compliant
- 1 HDMI input
- 1 VGA input with 3.5mm mini-jack audio input
- Supports HDMI input resolutions up to 4K@60Hz (4:4:4, 8-bit)
- Supports VGA input resolutions up to WUXGA (RB)
- Automatic conversion of 4K@50/60Hz HDMI sources to 4K@30Hz (4:4:4, 8-bit) for transmission over HDBaseT
- Automatic scaling of sources to match the native resolution of the HDMI display based on EDID
- HDBaseT feature support: HD Video and Audio, 48V PoH, and Control (Ethernet bypass)
- Simultaneous transmission of uncompressed video, audio and data over a single 100m Cat.5e/6/7 cable at 1080p and 70m at 4K
- Automatic input selection with hot plug detection enabling handsfree operation
- Unit may be powered locally or via 48V PoH (PD) from a compatible HDBaseT Receiver (PSE)
- Wall plate is designed for UK two-gang sized enclosures
- Controllable via front panel buttons and RS-232 (remote only)
- Front panel LEDs indicate input selection, power and link status

Receiver

- HDMI 2.0 and DVI 1.0 compatible
- HDCP 2.2 and HDCP 1.x compliant
- Supports resolutions up to 4K@50/60Hz (YUV 4:2:0, 8-bit)
- Supports CEC bypass
- Simultaneous reception of uncompressed video, audio and data over a single 100m Cat.5e/6/7 cable at 1080p and 70m at 4K
- HDBaseT feature support: HD Video and Audio, 48V PoH, and Control (Ethernet, IR and RS-232 bypass)
- Supports standard 48V PoH from Receiver (PSE) to Transmitter (PD) (compatible Transmitters only)

Notes:

- *The 48V PoH function is designed to power compatible Transmitter units only. Non-PoH Transmitters will need their own power supply. Other Transmitter brands may not be compatible.*
- *The use of "Premium High Speed HDMI" cables is highly recommended for displaying 3D and 4K content. Compatible display equipment is also required.*

6. OPERATION CONTROLS AND FUNCTIONS

6.1 Transmitter's Front Panel

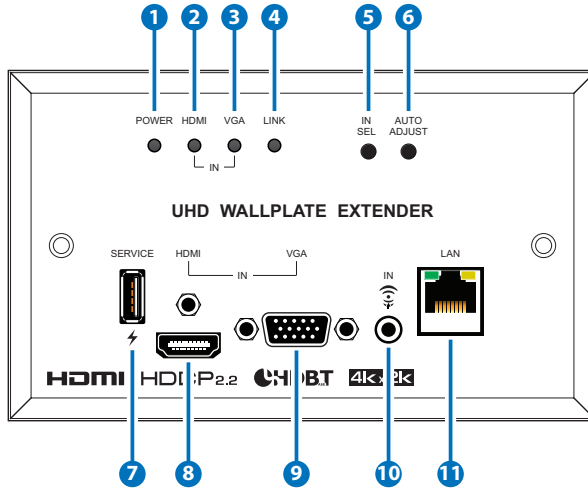

- 1 POWER LED:** This LED will illuminate to indicate the unit is on and receiving power.
- 2 HDMI IN LED:** This LED will illuminate when HDMI is the selected source.
- 3 VGA IN LED:** This LED will illuminate when VGA is the selected source.
- 4 LINK LED:** This LED will illuminate solid when both Transmitter and Receiver are connected and communicating with each other properly.
- 5 IN SEL:** Press this button to switch between the available inputs. The LED will illuminate to indicate which source is currently selected.
- 6 AUTO ADJUST:** Press this button to optimize the positioning of the picture (VGA sources only).

Note: Pressing and holding the Auto Adjust button for 5 seconds while the HDMI input is selected will reset the unit to its factory defaults.

- 7 SERVICE:** This slot is reserved for firmware update use only.
- 8 HDMI IN:** Connect to HDMI source equipment such as a media

player, game console or set-top box.

- 9 **VGA IN:** Connect to VGA source equipment such as a PC or laptop.
- 10 **AUDIO IN:** Connect to the stereo analog output of a device such as a CD player or PC for embedding into the HDBaseT output.
- 11 **LAN:** Connect directly, or through a network switch, to your PC/ laptop to control the unit.

6.2 Transmitter's Rear Panel

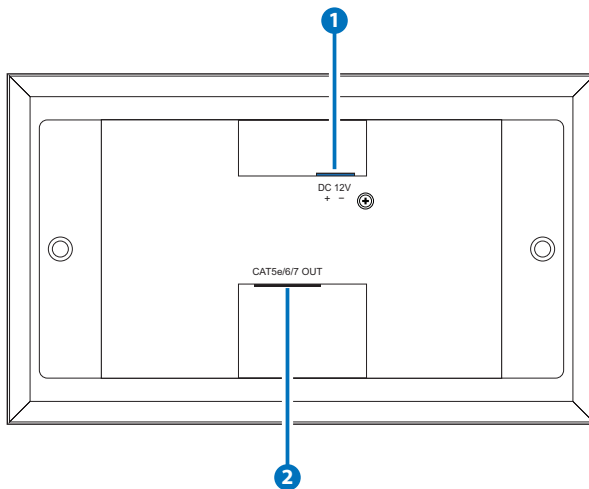

- 1 **DC 12V:** Plug a 12V DC power adapter into this port and connect it to an AC wall outlet for power (optional, not required when powered by PoH).
- 2 **CAT5e/6/7 OUT:** Connect to a compatible HDBaseT Receiver with a single Cat.5e/6/7 cable for transmission of all data signals.

6.3 Receiver's Front Panel

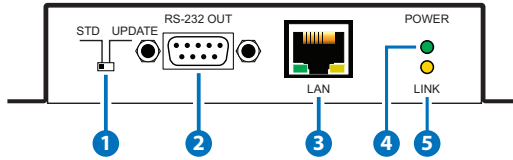

- 1 STD/UPDATE:** This switch is reserved for factory use only.
- 2 RS-232 OUT:** Connect to a PC, laptop or other serial control device to send control commands to a compatible Transmitter.
- 3 LAN:** Connect to an Ethernet device or to your local network as appropriate.
- 4 POWER LED:** This LED will illuminate to indicate the unit is on and receiving power.
- 5 LINK LED:** This LED will illuminate solid when both Transmitter and Receiver are connected and communicating with each other properly.

6.4 Receiver's Rear Panel

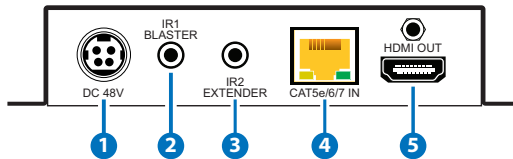

- 1 DC 48V:** Plug the 48V DC power adapter into this port and connect it to an AC wall outlet for power.
- 2 IR1 BLASTER:** Connect to the supplied IR Blaster cable for IR signal transmission. Place the IR Blaster in direct line-of-sight of the equipment to be controlled. (Requires compatible Transmitter.)
- 3 IR2 EXTENDER:** Connect to the supplied IR Extender cable for IR signal reception. Ensure that remote being used is within the direct line-of-sight of the IR Extender. (Requires compatible Transmitter.)
- 4 CAT5e/6/7 IN:** Connect to a compatible HDBaseT Transmitter with a single Cat.5e/6/7 cable for transmission of all data signals.
- 5 HDMI OUT:** Connect to an HDMI TV, monitor or amplifier for digital video and audio output.

6.5 RS-232 Protocol

TX		RX	
Pin	Pinout	Pin	Pinout
1		1	
2	TxD	2	RxD
3	RxD	3	TxD
4		4	
5	GND	5	GND
6		6	
7		7	
8		8	
9		9	

6.6 RS-232 Commands

COMMAND	DESCRIPTION AND PARAMETERS
HELP	Show the full command list.
?	Show the full command list.
GET FW VER	Show the unit's firmware version.
GET MODEL NAME	Show the unit's model name.
SET FACTORY DEFAULT	Reset all settings to the factory defaults.
SET OUT A ROUTE N1	Select the input source. Available values for N1: 1 [HDMI] 2 [VGA]
GET OUT A ROUTE	Show the current input source.

COMMAND	DESCRIPTION AND PARAMETERS
SET OUT AUTO MODE N1	Set the auto source select mode. Available values for N1: 0 [OFF] 1 [Auto Switch]
GET OUT AUTO MODE	Show the current auto source select mode.
GET OUT AUTO MODE LIST	List all available auto source modes.
GET IN N1 TIMING	Show the video timing of the source connected to input N1. Available values for N1: 1 [HDMI] 2 [VGA]
GET IN TYPE LIST	List all available input types.
SET FIX TIMING MODE N1	Set the scaler's output mode. Available values for N1: 0 [Bypass] 1 [Auto] 2 [480P@60Hz] 3 [720P@50Hz] 4 [720P@60Hz] 5 [1080P@50Hz] 6 [1080P@60Hz] 7 [4K@24Hz] 8 [4K@25Hz] 9 [4K@30Hz]
GET FIX TIMING MODE	Show the scaler's current output mode.

COMMAND	DESCRIPTION AND PARAMETERS
SET FIX COLOR SPACE N1	Set the output color space. Available values for N1: 0 [RGB] 1 [YUV 4:4:4]
GET FIX COLOR SPACE	Show the current output color space.
GET OUT A TIMING	Show the video timing of the output.
SET AUDIO OUT A ROUTE N1	Select the audio source. Available values for N1: 1 [HDMI Audio] 2 [Analog Audio]
GET AUDIO OUT A ROUTE	Show the currently selected audio source.
GET AUDIO IN TYPE LIST	List all available audio sources.
SET IN 1 HDCP MODE N1	Set the HDCP mode for the HDMI input. Available values for N1: 0 [Disable HDCP] 1 [Follow Source] 2 [Follow Display]
GET IN 1 HDCP MODE	Show the current HDCP mode for the HDMI input.
SET IN 1 EDID N1	Set the EDID to use with the HDMI input. Available values for N1: 1 [1080P, 2CH] 2 [4K (3G), 2CH] 3 [4K (6G), 2CH] 4 [Output's EDID]



COMMAND	DESCRIPTION AND PARAMETERS
GET IN 1 EDID	Show the currently selected EDID source for the HDMI input.
GET IN EDID LIST	List all available EDID sources.

Note: Commands will not be executed unless followed by a carriage return. Commands are not case-sensitive.

7. CONNECTION DIAGRAM

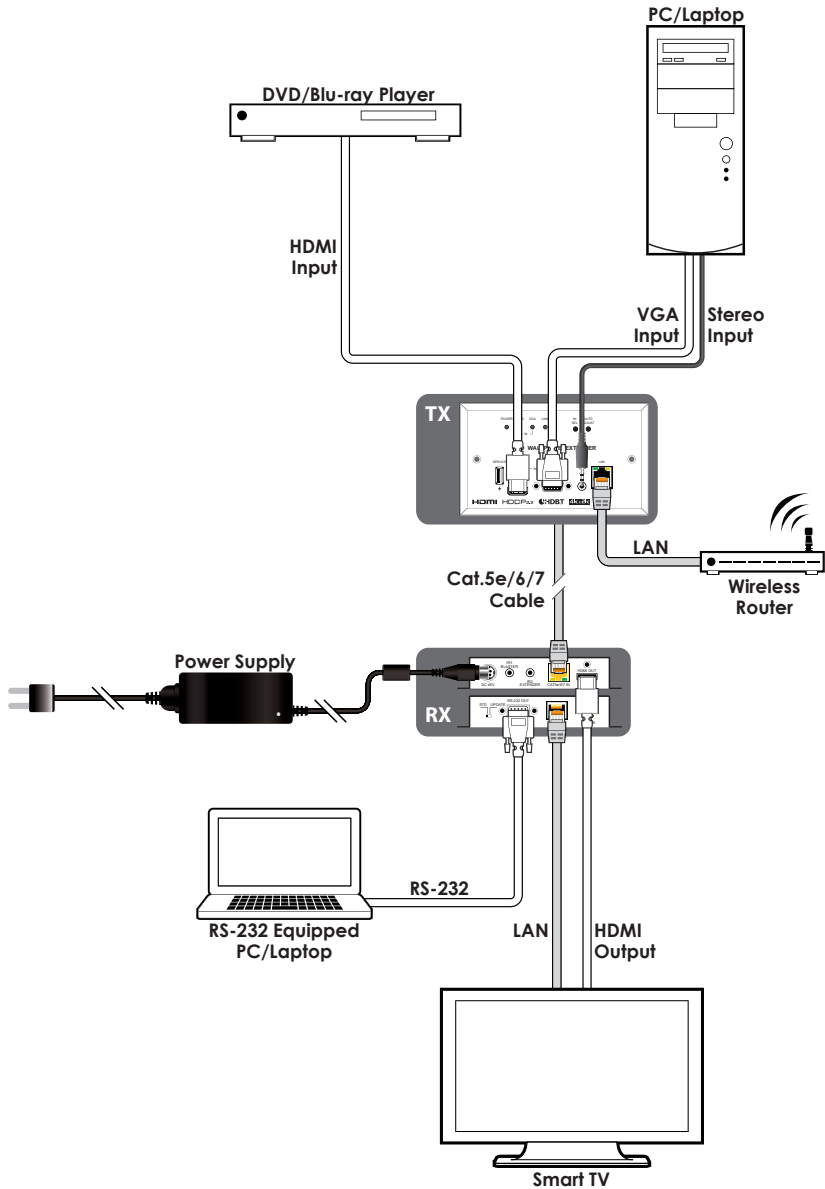



8. SPECIFICATIONS

8.1 Transmitter's Technical Specifications

HDMI Bandwidth	600MHz/18Gbps
HDBaseT Bandwidth	340Hz/10.2Gbps
Input Ports	1×HDMI 1×VGA 1×3.5mm (Stereo Audio)
Output Port	1×Cat.5e/6/7
Pass-through Port	1×LAN [RJ-45]
Baud Rate	19200bps
Power Supply	12V/3A DC (US/EU standards, CE/FCC/ UL certified)
ESD Protection	Human Body Model: ±8kV (Air Discharge) ±4kV (Contact Discharge)
Dimensions	147mm×87.5mm×41.5mm (W×H×D) [Case Only] 147mm×87.5mm×46.6mm (W×H×D) [All Inclusive]
Weight	250g
Chassis Material	Metal
Silkscreen Color	White
Operating Temperature	0°C - 40°C/32°F - 104°F
Storage Temperature	-20°C - 60°C/-4°F - 140°F
Relative Humidity	20 - 90% RH (Non-condensing)
Power Consumption	26.84W

8.2 Receiver's Technical Specifications

HDMI Bandwidth	600MHz/18Gbps
HDBaseT Bandwidth	340Hz/10.2Gbps
Input Port	1×Cat.5e/6/7
Output Port	1×HDMI
Pass-through Ports	1×IR Extender [3.5mm] 1×IR Blaster [3.5mm] 1×RS-232 [9-pin D-sub] 1×LAN [RJ-45]
IR Frequency	30 - 50kHz (30 - 60kHz under ideal conditions)
Baud Rate	Up to 115200bps
Power Supply	48V/0.83A DC (US/EU standards, CE/FCC/UL certified)
ESD Protection	Human Body Model: ±8kV (Air Discharge) ±4kV (Contact Discharge)
Dimensions	128mm×25mm×108mm (W×H×D) [Case Only] 128mm×25mm×117m (W×H×D) [All Inclusive]
Weight	366g
Chassis Material	Metal
Silkscreen Color	Black
Operating Temperature	0°C - 40°C/32°F - 104°F
Storage Temperature	-20°C - 60°C/-4°F - 140°F
Relative Humidity	20 - 90% RH (Non-condensing)
Power Consumption	8.74W

8.3 Video Specifications

Supported PC Resolutions (Hz)		Input		Output
		HDMI	VGA	HDMI via HDBaseT
640×480	60, 72, 75, 85	✓	✓	✓
720×400	85	✓	✓	✓
800×600	56, 60, 72, 75, 85	✓	✓	✓
1024×768	60, 70, 75, 85	✓	✓	✓
1152×864	75	✓	✓	✓
1280×768	60, 75, 85	✓	✓	✓
1280×800	60 (RB), 60	✓	✓	✓
1280×960	60	✓	✓	✓
1280×1024	60	✓	✓	✓
1360×768	60	✓	✓	✓
1366×768	60 (RB), 60	✓	✓	60 (RB)
1400×1050	60 (RB), 60	✓	✓	✓
1440×900	60 (RB), 60	✓	✓	✓
1600×1200	60	✓	✓	✓
1680×1050	60 (RB), 60	✓	✓	✓
1920×1200	60	✓	✓	✓
1920×1440	60	✓	✗	✓
2560×1600	60	✓	✗	✓

Supported TV Resolutions (Hz)		Input		Output
		HDMI	VGA	HDMI via HDBaseT
720×480i	59.94, 60	✓		
720×576i	50	✓		
720×480p	59.94, 60	✓	✓	✓
720×576p	50	✓	✓	✓
1280×720p	50, 59.94, 60	✓	✓	✓
1920×1080i	50, 59.94, 60	✓		
1920×1080p	23.97, 24, 25, 29.97, 30	✓	✓	✓
	50, 59.94, 60	✓	✓	✓
3840×2160p (YUV 4:2:0)	50, 59.94, 60	✓		
4096×2160p (YUV 4:2:0)	50, 59.94, 60	✓		
3840×2160p	24, 25, 30	✓		✓
	50, 59.94, 60	✓		
4096×2160p	24, 25, 30	✓		✓
	50, 59.94, 60	✓		

8.4 Cable Specifications

HDMI Cable Length (meter)	1080p		4K
	8-bit	12-bit	8-bit
Input	10	10	5
Output	10	10	5

Cat. Cable Length (meter)	1080p	4K
Cat.5e	100	70
Cat.6	100	70
Cat.7	100	100

- **Full HD Video (1080p)**
 - Up to 1080p@60Hz, 12-bit color
 - Data rates lower than 5.3Gbps or below 225MHz TMDS clock
- **Ultra HD Video (4K)**
 - 4K@24/25/30Hz & 4K@50/60Hz (YUV 4:2:0), 8-bit color
 - Data rates higher than 5.3Gbps or above 225MHz TMDS clock

9. ACRONYMS

ACRONYM	COMPLETE TERM
Cat.5e	Category 5 (enhanced) Cable
Cat.6	Category 6 Cable
Cat.7	Category 7 Cable
CEC	Consumer Electronics Control
DVI	Digital Visual Interface
HD	High-Definition
HDCP	High-bandwidth Digital Content Protection
HDMI	High-Definition Multimedia Interface
IR	Infrared
LAN	Local Area Network
LPCM	Linear Pulse-Code Modulation
PD	Powered Device
PoH	Power over HDBaseT
PSE	Power Sourcing Equipment
UHD	Ultra-High-Definition
VGA	Video Graphics Array
WUXGA	Wide Ultra Extended Graphics Array



CYPRESS TECHNOLOGY CO., LTD.

www.cypress.com.tw